

COURSE: Medical Microbiology, MBIM 650 – Fall 2009

TOPIC: MHC and T cell receptors

Lecture #11

FACULTY: Dr. Jennifer Nyland
Office: Bldg #1, Room B10
Phone: 733-1586
Email: jnyland@uscmed.sc.edu

TEACHING OBJECTIVES:

1. To give an overview of the role of MHC in immune response
2. To describe the structure and function of the MHC
3. To describe the structure and function of the TCR
4. To discuss the genetic basis for generation of diversity in the TCR
5. To describe the nature of the immunological synapse and the requirements for T cell activation

REQUIRED READING:

Male, *et al.* Immunology, 7th Ed., Cpt 5 and pp 152-157.

KEY WORDS:

MHC class I and class II molecules, Polymorphism, Anchor sites, HLA, TCR, Diversity, CD3 complex, Immunological synapse, Accessory molecules, Co-stimulation, Anergy, CD28, CD80 (B7-1), CD86 (B7-2), CD2, LFA, ICAM-1, CTLA-4.

MAJOR HISTOCOMPATIBILITY COMPLEX AND T CELL RECEPTORS

1) Role of MHC in the immune response

- a) Cell-cell interactions of the adaptive immune response are critically important in protection from pathogens. These interactions are orchestrated by the immunological synapse whose primary components are the T cell Ag receptor (TCR) and the Major histocompatibility complex (MHC) molecule. The major function of the TCR is to recognize Ag in the correct context of MHC and to transmit an excitatory signal to the interior of the cell. Since binding of peptide within the MHC is not covalent, there are many factors which help stabilize the immunological synapse.
- b) There are two types of MHC (class I and class II) which are recognized by different subsets of T cells. The cytotoxic T cell (CTL) recognizes Ag peptide in the context of MHC class I. The T helper cell (Th) recognizes Ag presented in MHC class II.

2) Structure of MHC class I

- a) The molecule: Class I MHC molecules are composed of two polypeptide chains, a long α chain and a short β chain called β 2-microglobulin (Figure 1). The α chain has four regions. First, a cytoplasmic region, containing sites for phosphorylation and binding to cytoskeletal elements. Second, a transmembrane region containing hydrophobic amino acids by which the molecule is anchored in the cell membrane. Third, a highly conserved α 3 immunoglobulin (Ig)-like domain to which CD8 binds. Fourth, a highly polymorphic peptide binding region formed from the α 1 and α 2 domains. The β 2- microglobulin associates with the α chain and helps maintain the proper conformation of the molecule.

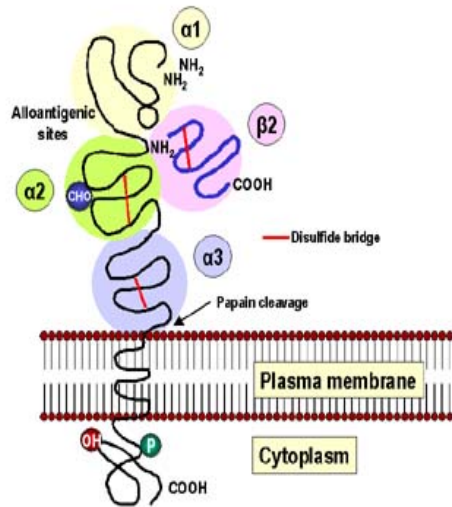

Fig 1.

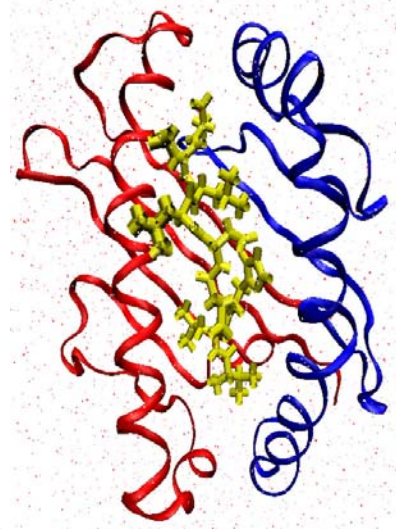

Fig 2.

- b) The Ag-binding groove: An analysis of which part of the class I MHC molecules is most variable demonstrates that variability is most pronounced in the α 1 and α 2 domains, which comprise the peptide binding region (Figure 2). The structure of the peptide binding groove, revealed by X-ray crystallography, shows that the groove is composed of two α helices forming a wall on each side and eight β -pleated sheets forming a floor. The peptide is bound in the groove and the residues that line the groove make contact with the peptide. These are the residues that are the most polymorphic. The groove will accommodate peptides of approximately 8-10 amino acids long. Whether a particular peptide will bind to the groove will depend on the amino acids that line the groove. Because class I molecules are polymorphic, different class I molecules will bind many different peptides. Each class I molecule will bind only certain peptides and will have a set of criteria that a peptide must have in order to bind to the groove. For every class I molecule, there are certain amino acids that must be at a particular location in the peptide before it will bind to the MHC molecule. Interactions at the N and C-terminus of the peptide are critical and “lock” the peptide within the groove. These sites in the peptide are referred to as the “anchor sites”. The ends of the peptide are buried within the closed ends of the class I binding groove while the center bulges out for presentation to the TCR.

3) Structure of MHC class II

- a) The molecule: Class II MHC molecules are composed of two polypeptide chains, an α and a β chain of approximately equal length (Figure 3). Both chains have four regions: first, a cytoplasmic region containing sites for phosphorylation and binding to cytoskeletal elements; second, a transmembrane region containing hydrophobic amino acids by which the molecule is anchored in the cell membrane, third, a highly conserved $\alpha 2$ domain and a highly conserved $\beta 2$ domain to which CD4 binds and fourth, a highly polymorphic peptide binding region formed from the $\alpha 1$ and $\beta 1$ domains.

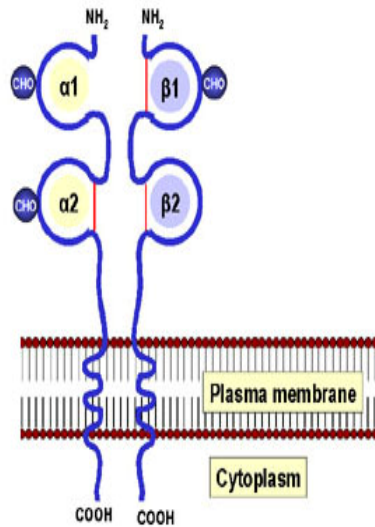

Fig 3.

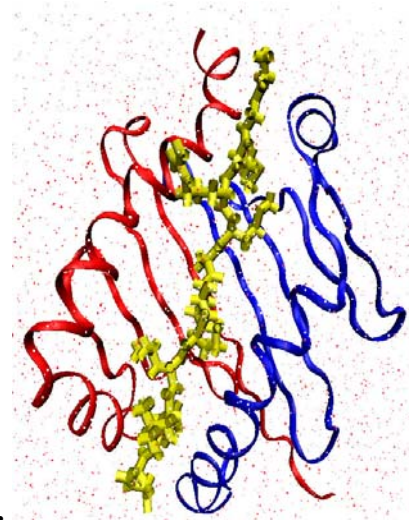

Fig 4.

- b) The Ag-binding groove: As with Class I MHC molecules, an analysis of which part of the class II MHC molecule is most variable demonstrates that variability is most pronounced in the $\alpha 1$ and $\beta 1$ domains, which comprise the peptide binding region (Figure 4). The structure of the peptide binding groove, revealed by X-ray crystallography, shows that, like class I MHC molecules, the groove is composed of two α helices forming a wall on each side and eight β -pleated sheets forming a floor. Both the $\alpha 1$ and $\beta 1$ chain contribute to the peptide binding groove. The peptide is bound in the groove and the residues that line the groove make contact with the peptide. These are the residues that are the most polymorphic. The groove of Class II molecules is open at one end so that the groove can accommodate longer peptides of approximately 13-25 amino acids long with some of the amino acids located outside of the groove. Whether a particular peptide will bind to the groove will depend on the amino acids that line the groove. Because class II molecules are polymorphic, different class II molecules will bind different peptides. Like class I molecules, each class II molecule will bind only certain peptides and will have a set of criteria that a peptide must have in order to bind to the groove (i.e. “anchor sites”).

4) Important aspects of MHC

- a) Although there is a high degree of polymorphism for a species, an individual has maximum of six different class I MHC products and only slightly more class II MHC products (considering only the major loci). Each MHC molecule has only one binding site. The different peptides a given MHC molecule can bind all bind to the same site, but

only one at a time. Because each MHC molecule can bind many different peptides, binding is termed degenerate. MHC polymorphism is determined only in the germline. There are no recombinatorial mechanisms for generating diversity. MHC molecules are membrane-bound; recognition by T cells requires cell-cell contact. Alleles for MHC genes are co-dominant. Each MHC gene product is expressed on the cell surface of an individual nucleated cell. A peptide must associate with a given MHC of that particular individual otherwise no immune response can occur. Mature T cells must have a T cell receptor that recognizes the peptide associated with MHC. Cytokines (especially interferon- γ) increase level of expression of MHC. Polymorphism in MHC is important for survival of the species.

- b) How do peptides get into the MHC groove (Figure 5)? Peptides from the cytosol associate with class I MHC and are recognized by CTL cells. The peptides enter the endoplasmic reticulum and bind in the MHC class I groove. This complex is then exported to the cell surface through the golgi. MHC class II molecules are formed with an invariant (Ii) chain as a place holder while in the ER and golgi. The Ii chain is cleaved and removed once the complex is in a vesicle. Peptides from within the vesicle associate with class II MHC and are then exported to the cell surface where they are recognized by Th cells.

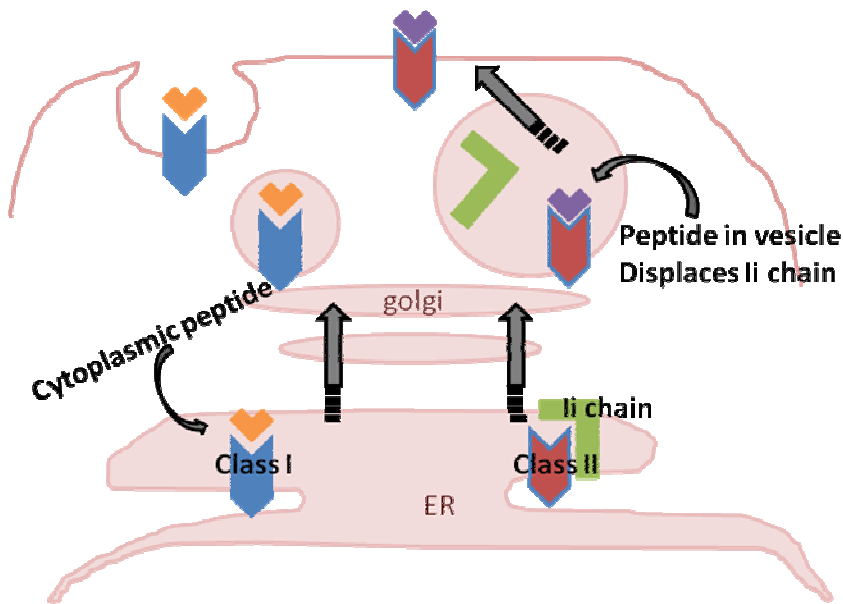

Figure 5.

5) Role of TCR in the immune response

- a) The TCR is a surface molecule found on T cells that recognizes Ag presented in the correct MHC context. The TCR is similar to immunoglobulin (Ig) and is part of the Ig superfamily. There are two types of TCRs, the predominant $\alpha\beta$ which is commonly found in lymphoid tissues, and the $\gamma\delta$ which is found at mucosal surfaces.

6) Structure of the TCR ($\alpha\beta$)

- a) The TCR is a heterodimer composed of one α and one β chain of approximately equal length (Figure 6). Each chain has a short cytoplasmic tail but it is too small to be able to transduce an activation signal to the cell. Both chains have a transmembrane region comprised of hydrophobic amino acids by which the molecule is anchored in the cell membrane. Both chains have a constant region and a variable region similar to the immunoglobulin chains. The variable region of both chains contains hypervariable regions that determine the specificity for antigen.

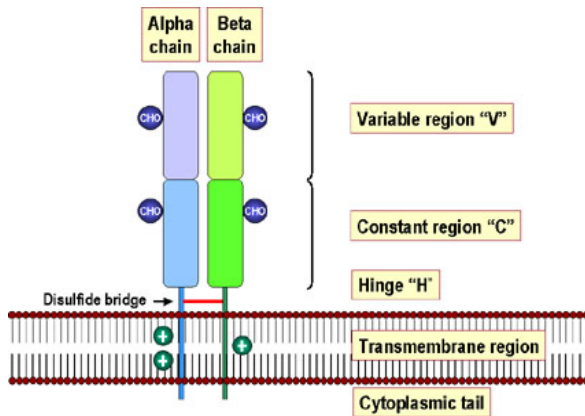

Figure 6.

7) Important aspects of the TCR

- a) Each T cell bears a TCR of only one specificity (*i.e.* there is allelic exclusion). The $\alpha\beta$ TCR recognizes Ag only in the context of cell-cell interaction and in the correct MHC. The $\gamma\delta$ TCR recognizes Ag in an MHC-independent manner in response to certain viral and bacterial Ag.

8) Genetic basis for receptor generation

- a) The genetic basis for the generation of the vast array of antigen receptors on B cells has been discussed previously (see lecture on Ig genetics). The generation of a vast array of TCRs is accomplished by similar mechanism. The germline genes for the TCR β genes are composed of V, D and J gene segments that rearrange during T cell development to produce many different TCR β chains (Figure 7). The germline genes for the TCR α genes are composed of V and J gene segments which rearrange to produce α chains. The specificity of the TCR is determined by the combination of α and β chains.

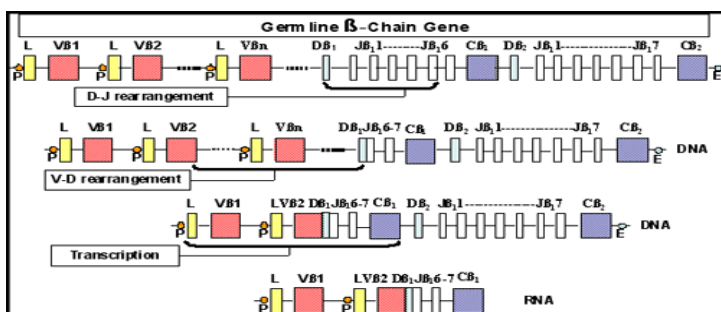

Figure 7.

9) TCR and CD3 complex

- a) The TCR is closely associated with a group of 5 proteins collectively called the CD3 complex (Figure 8). The CD3 complex is composed of one γ , one δ , two ϵ and 2 ζ chains. All of the proteins of the CD3 complex are invariant and they do not contribute to the Ag specificity in any way. The CD3 complex is necessary for cell surface expression of the TCR during T cell development as it stabilizes the receptor. In addition, the CD3 complex transduces activation signals to the cell following antigen interaction with the TCR.

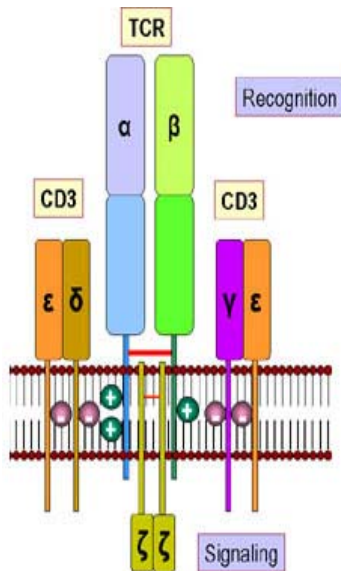

Fig 8.

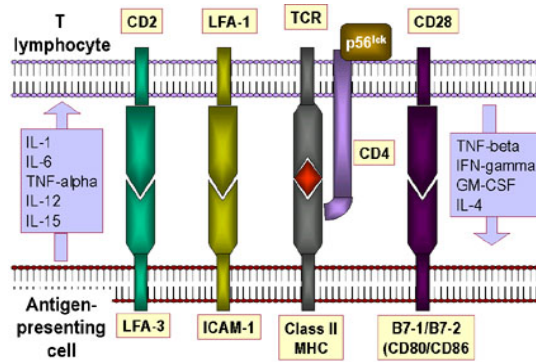

Fig 9.

10) The “immunological synapse”

- a) The interaction between the TCR and MHC molecules are not very strong. Accessory molecules are necessary to help stabilize the interaction (Figure 9). These include: 1) CD4 binding to Class II MCH, which ensures that Th cells only interact with APCs; 2) CD8 binding to Class I MHC, which ensures that CTL cells can interact with target cells; 3) CD2 binding to LFA-3; and 4) LFA-1 binding to ICAM-1. The accessory molecules are invariant and do not contribute to the specificity of the interaction, which is solely determined by the TCR. The expression of accessory molecules can be increased in response to cytokine, which is one way that cytokines can modulate immune responses.
- b) In addition to accessory molecules which help stabilize the interaction between the TCR and antigen in association with MHC molecules, other molecules are also needed for T cell activation. Two signals are required for T cell activation – one is the engagement of the TCR with Ag/MHC and the other signal comes from the engagement of co-stimulatory molecules with their ligands. One of the most important (but not the only) co-stimulatory molecule is CD28 on T cells which must interact with B7-1 (CD80) or B7-2 (CD86) on APCs. Like accessory molecules the co-stimulatory molecules are invariant and do not contribute to the specificity of the interaction. The multiple interactions of TCR with Ag/MHC and the accessory and co-stimulatory molecules with their ligands have been termed the “immunological synapse.”

- c) Not only is co-stimulation necessary for T cell activation, a lack of co-stimulation may result in anergy (i.e., inability to respond to antigen) or down-regulation of the response. There are a number of possible outcomes of a T cell receiving one or both of the signals necessary for activation. Engagement of the TCR with Ag/MHC but no co-stimulation results in anergy. Engagement of only the co-stimulatory molecule has no effect. Engagement of TCR with Ag/MHC and co-stimulatory molecules with their ligand results in activation. Engagement of the TCR with Ag/MHC and engagement of B7 ligand with CTLA-4, molecules similar to CD28, results in down-regulation of the response. CTLA-4/B7 interaction sends an inhibitory signal to the T cell rather than an activating signal. This is one of the ways that immune responses are regulated. CTLA-4 is expressed on T cells later in an immune response and this helps to turn off the response.

11) Key steps in T cell activation

- a) The APC must process and present peptides to T cells. T cells must receive a co-stimulatory signal, usually from CD28/CD80 or CD86 interaction. Accessory adhesion molecules must help to stabilize the binding of T cells and the APC. Signals from the cell surface must be transmitted to the nucleus via second messengers. Cytokines, produced by the activated cell, help to drive cell proliferation.